

Panasonic

SDI output Board

AJ-YA901^{PE}_{EN}

Installation Guide

ENGLISH

DEUTSCH

FRANÇAIS

ITALIANO

ESPAÑOL

日本語

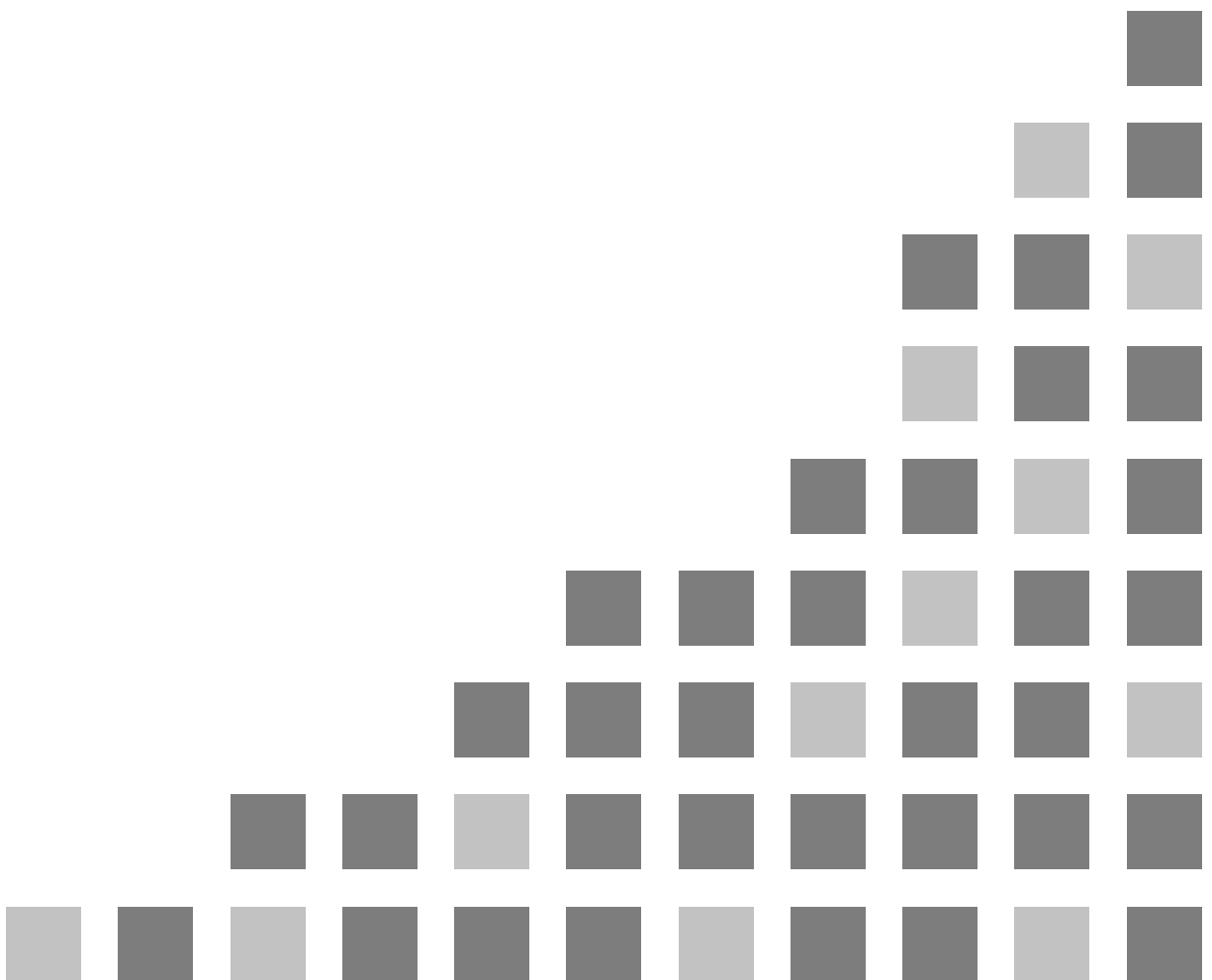

Overview/Connector Area

Overview

AJ-YA901P/E

This SDI output board is designed for use with the AJ-BS900. Its installation in the AJ-BS900 enables digital data output using the SDI format.

Refer the installation of the SDI output board to qualified service personnel.

Connector Area (AJ-BS900)

Serial digital output connectors (BNC x2)

- ❶ Output 1: SDI output
- ❷ Output 2: SDI output

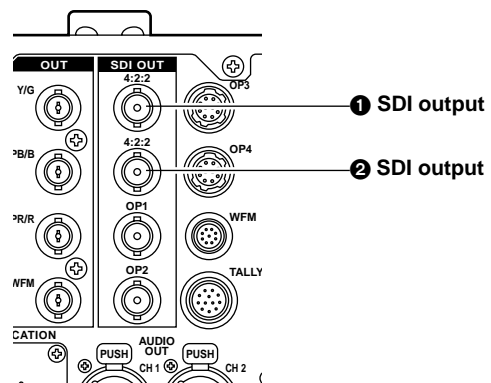

Installation

Follow the steps below to install the AJ-YA901 (referred to below as “the board”) in the AJ-BS900.

1. Refer to the figure below, and remove the four screws from the rear panel of the AJ-BS900.

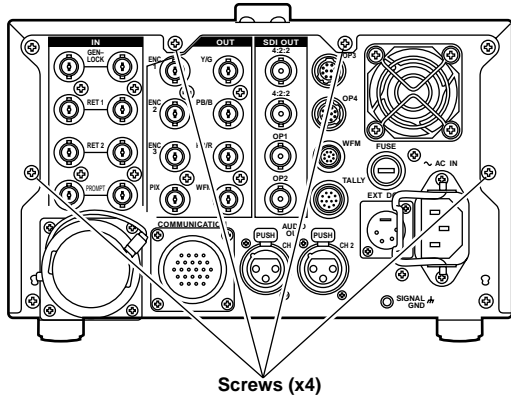

4. Pass the ends of the cables attached to the board from the position at the bottom shown in the figure below toward the top of the rear panel.

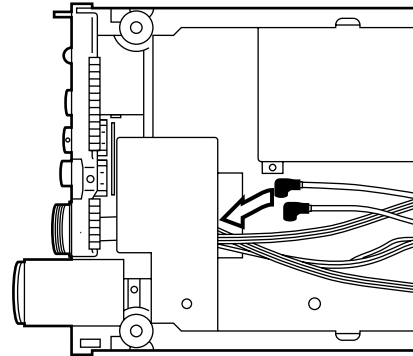

2. Remove the two screws each from the left and right side panels of the AJ-BS900 to remove the side panels.

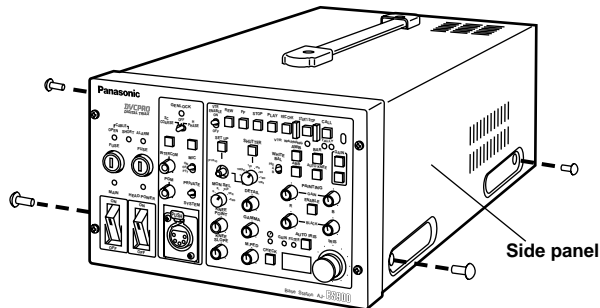

5. Connect the cables, which were inserted into the AJ-BS900 in step 4, on the inner side of the SDI output connectors. For details on the positions of these connectors, refer to the figure below and to “Connector Area” (page E-1).

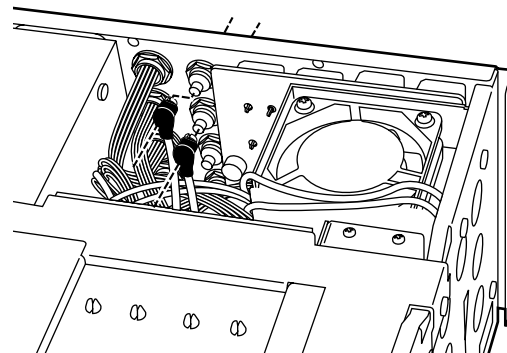

3. Remove the two screws from the bottom panel of the AJ-BS900 to remove the bottom panel.

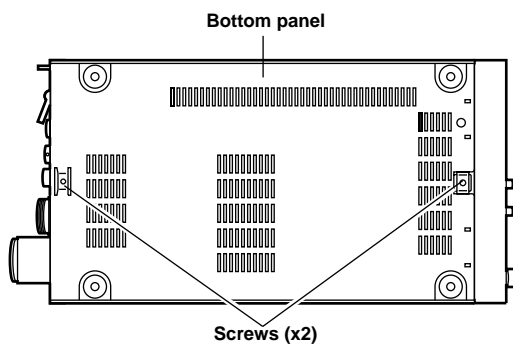

6. Remove the four screws on the front panel of the AJ-BS900, and pull off the front panel cover. (The screws cannot be removed from the front panel cover.)

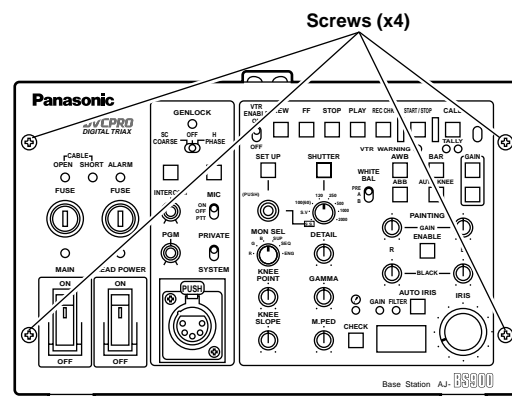

Installation

- 7.** While referring to the figure below, pass the other ends of the cables connected in step 5 from the bottom toward the front panel top.

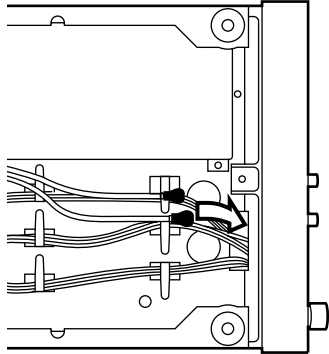

- 10.** Insert the board into the left-most slot of the AJ-BS900, and reattach the metal piece, which was disengaged in step 8, to its original position. When securing the metal piece, ensure that the cables are not pinched.

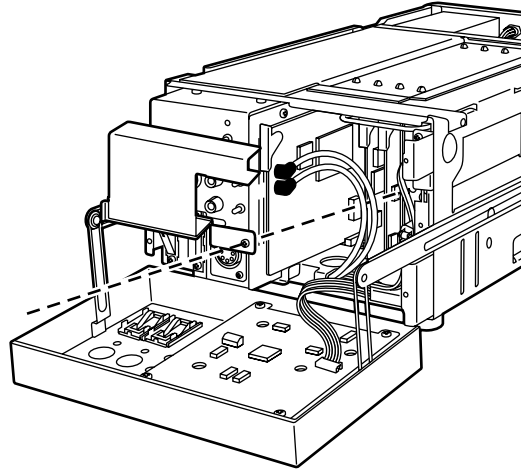

- 8.** Remove the screw from the front panel of the cover removed from the AJ-BS900, and disengage the metal piece shown in the figure below. (The screw cannot be removed from the metal piece.)

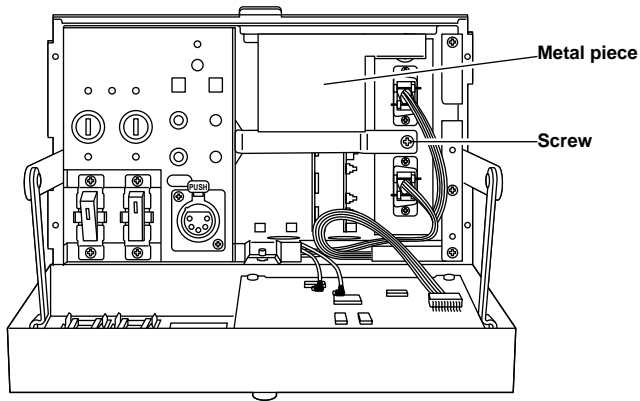

- 11.** Pull out the excess lengths of the cables toward the bottom, and anchor the cables using cable clamps so that no slack remains in the cables.

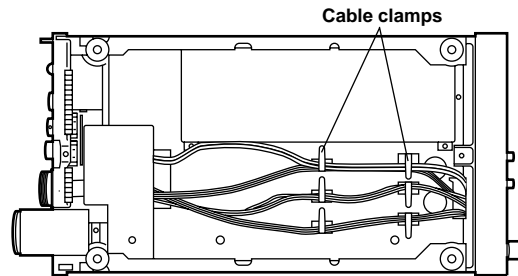

- 9.** Connect the ends of the cables which were passed from the bottom in step 7 to the board so that they are aligned in the directions shown in the figure below.

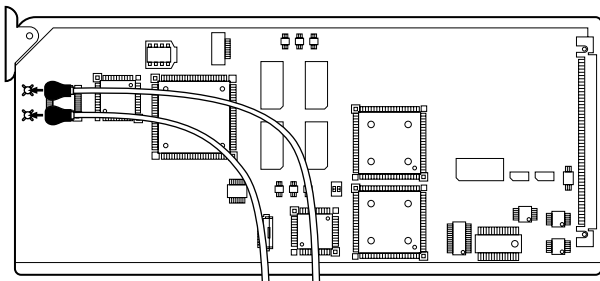

- 12.** Return the front panel cover, bottom panel and side panels in this order to their original positions, and secure them using the respective screws.

Specifications

Specifications

GENERAL

Weight: 170 g
Dimensions: 230 (W) x 113 (H) x 20 (D) mm

VIDEO OUTPUT

Serial digital output connectors: BNC x 2
SERIAL OUT 1: SDI output connector
SERIAL OUT 2: SDI output connector
SDI: Compliant with SMPTE 259M-C standard

AUDIO OUTPUT

Serial digital output connectors: Compliant with SMPTE 259M-C/SMPTE 272M-A standards

Übersicht/Anschlussbereich

Übersicht

AJ-YA901P/E

Diese SDI-Ausgangsplatine ist für den Einsatz mit dem AJ-BS900 vorgesehen. Ihr Einbau in den AJ-BS900 ermöglicht die digitale Datenausgabe im SDI-Format.

Überlassen Sie den Einbau der SDI-Ausgangsplatine qualifiziertem Wartungspersonal.

Anschlussbereich (AJ-BS900)

Serielle Digitalausgänge (BNC x 2)

- ❶ Ausgang 1: SDI-Ausgang
- ❷ Ausgang 2: SDI-Ausgang

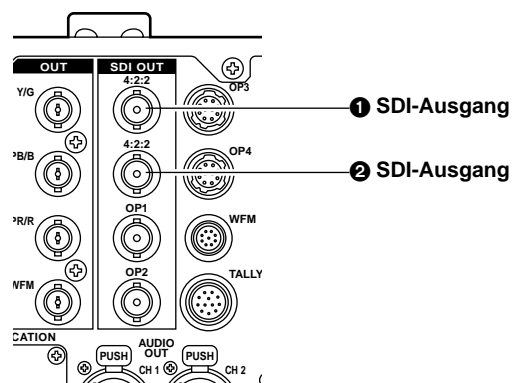

Installation

Führen Sie die folgenden Schritte aus, um die Platine AJ-YA901 in den AJ-BS900 einzubauen.

- Die in der nachstehenden Abbildung gezeigten vier Schrauben von der Rückwand des AJ-BS900 entfernen.

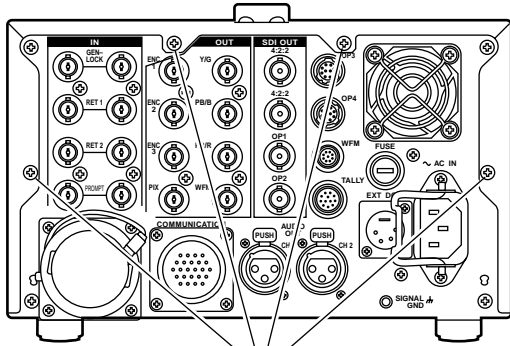

Schrauben (x 4)

- Die Enden der an der Platine angebrachten Kabel von der in der folgenden Abbildung gezeigten Position an der Unterseite zur Oberseite der Rückwand führen.

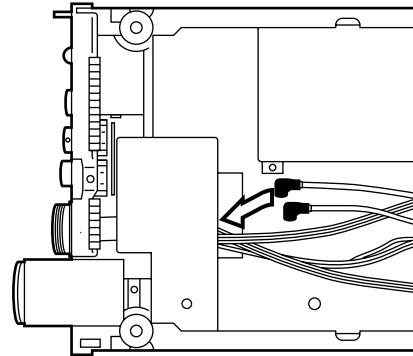

- Je zwei Schrauben von der linken und rechten Seitenwand des AJ-BS900 entfernen, und die Seitenwände abnehmen.

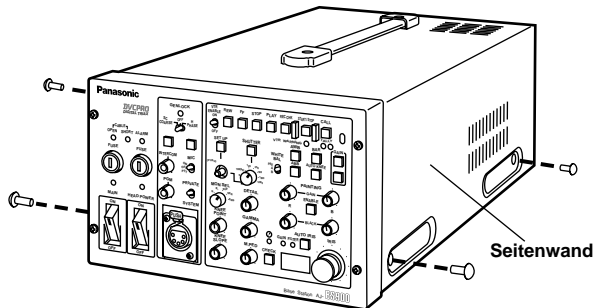

- Die in Schritt 4 in den AJ-BS900 eingeführten Kabel an der Innenseite der SDI-Ausgangsbuchsen anschließen. Einzelheiten zur Lage dieser Buchsen sind der folgenden Abbildung und dem Abschnitt "Anschlussbereich" (Seite D-1) zu entnehmen.

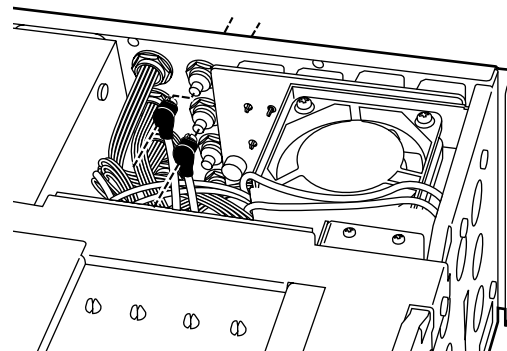

- Zwei Schrauben von der Bodenplatte des AJ-BS900 entfernen, und die Bodenplatte abnehmen.

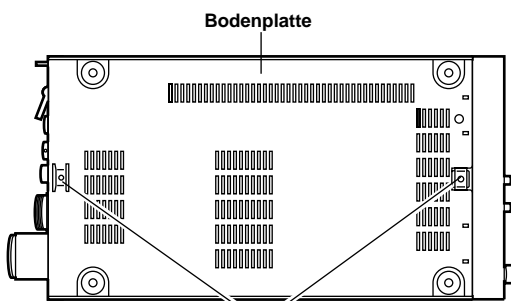

Schrauben (x 2)

- Die vier Schrauben von der Frontplatte des AJ-BS900 entfernen, und die Frontplattenabdeckung abziehen. (Die Schrauben können nicht von der Frontplattenabdeckung entfernt werden.)

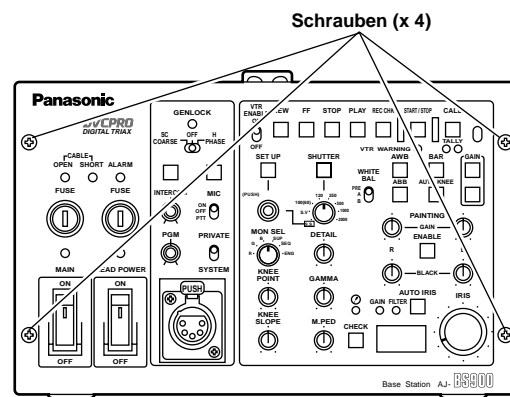

DEUTSCH

Installation

- 7.** Die anderen Enden der in Schritt 5 angeschlossenen Kabel gemäß der folgenden Abbildung von der Unterseite zur Oberseite der Frontplatte führen.

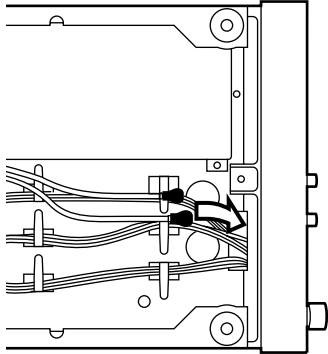

- 10.** Die Platine in den äußersten linken Steckplatz des AJ-BS900 einführen, und die in Schritt 8 abgenommene Metallplatte wieder an ihrem ursprünglichen Platz anbringen. Beim Befestigen der Metallplatte darauf achten, dass die Kabel nicht eingeklemmt werden.

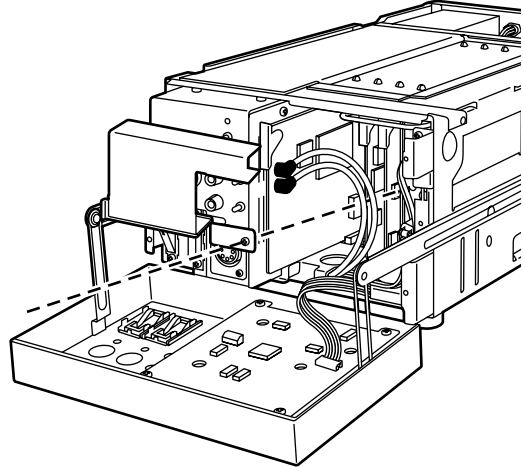

- 8.** Die markierte Schraube von der freigelegten Vorderseite des AJ-BS900 entfernen, und die in der folgenden Abbildung gezeigte Metallplatte abnehmen. (Die Schraube kann nicht von der Metallplatte entfernt werden.)

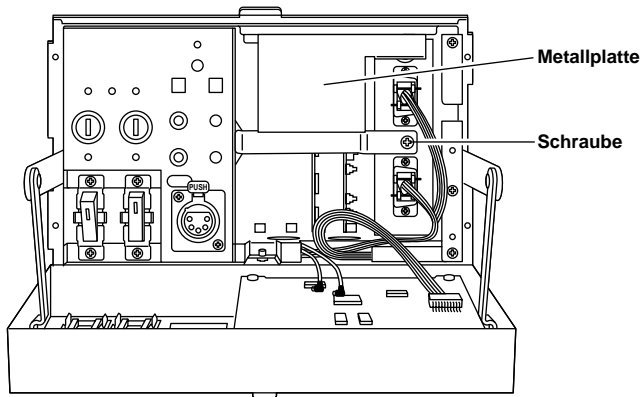

- 11.** Die überschüssigen Kabellängen nach unten ziehen, und die Kabel mit den Kabelklemmen so verankern, dass sie keinen Durchhang haben.

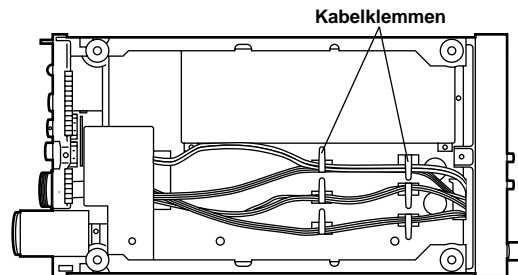

- 9.** Die Enden der in Schritt 7 von der Unterseite eingeführten Kabel so an die Platine anschließen, dass die Kabel gemäß der folgenden Abbildung verlaufen.

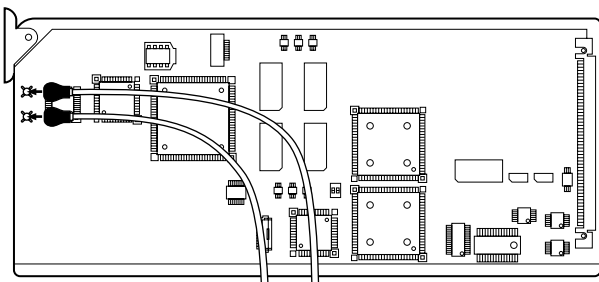

- 12.** Frontplattenabdeckung, Bodenplatte und Seitenwände in dieser Reihenfolge wieder anbringen und mit den jeweiligen Schrauben befestigen.

Technische Daten

Technische Daten

ALLGEMEINES

Gewicht: 170 g
Abmessungen: 230 (B) x 113 (H) x 20 (T) mm

VIDEO-AUSGÄNGE

Serielle Digitalausgänge: BNC x 2
SERIAL OUT 1: SDI-Ausgang
SERIAL OUT 2: SDI-Ausgang
SDI: Entspricht der Norm SMPTE 259M-C

AUDIO-AUSGANG

Serieller Digitalausgang: Entspricht den Normen SMPTE 259M-C/SMPTE 272M-A

Vue d'ensemble/Section des connecteurs

Vue d'ensemble

AJ-YA901P/E

La carte de sortie SDI a été conçue pour l'AJ-BS900. Son installation dans l'AJ-BS900 permet l'envoi des données numériques à l'aide du format SDI.

Confier l'installation de la carte de sortie SDI à un personnel qualifié.

Section des connecteurs (AJ-BS900)

Connecteurs de sortie numérique série (BNC x2)

- ❶ Sortie 1 : Sortie SDI
- ❷ Sortie 2 : Sortie SDI

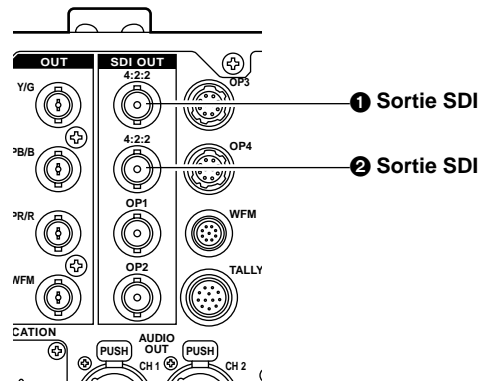

Installation

Pour installer l'AJ-YA901 (ci-après dénommée "la carte") dans l'AJ-BS900, procéder de la façon suivante.

1. Se reporter à la figure ci-dessous, et retirer les quatre vis du panneau arrière de l'AJ-BS900.

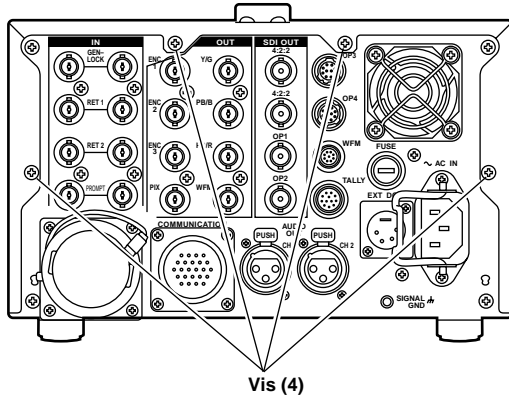

4. Faire passer les extrémités des câbles fixés à la carte de la position sur le panneau du fond indiquée sur la figure ci-dessous vers le haut du panneau arrière.

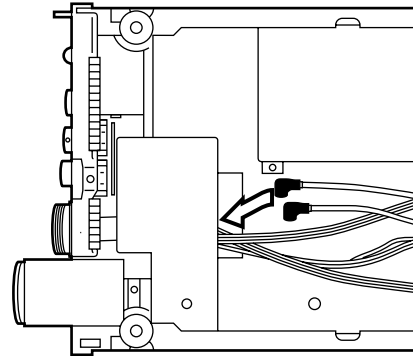

2. Retirer les deux vis sur chacun des panneaux latéraux gauche et droit de l'AJ-BS900 pour retirer les panneaux latéraux.

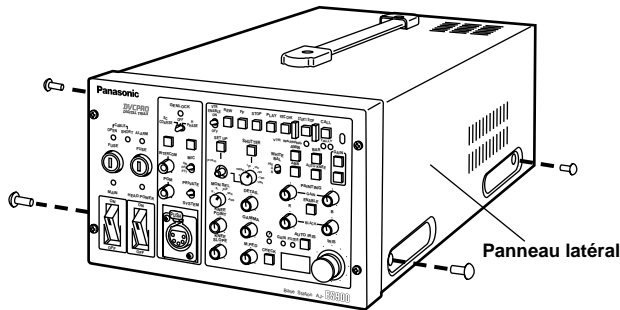

5. Raccorder les câbles, qui ont été insérés dans l'AJ-BS900 au point 4, au panneau interne des connecteurs de sortie SDI. Pour les détails sur l'emplacement des connecteurs, voir la figure ci-dessous et la "Section des connecteurs" (page F-1).

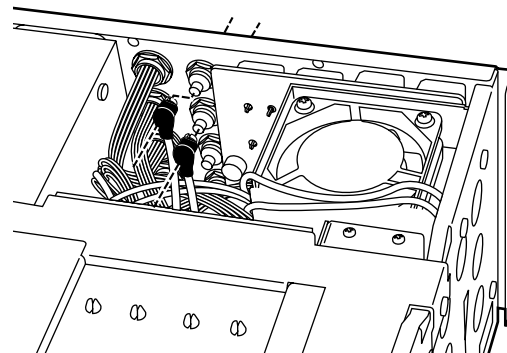

3. Retirer les deux vis du panneau inférieur de l'AJ-BS900 pour retirer le panneau inférieur.

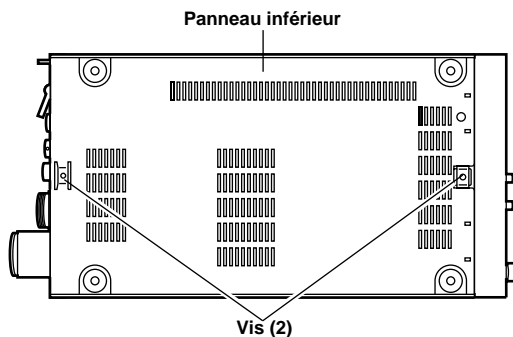

6. Retirer les quatre vis du panneau avant de l'AJ-BS900, et tirer sur le couvercle du panneau avant pour l'enlever. (La vis ne se détache pas du couvercle du panneau.)

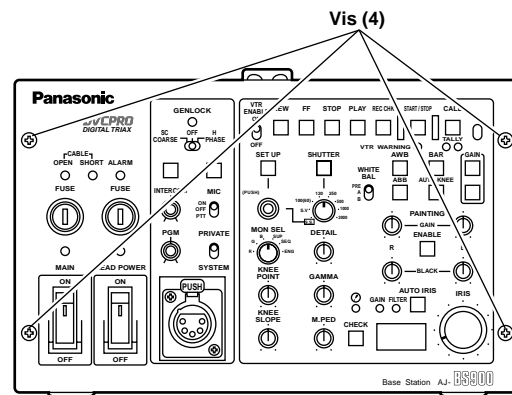

Installation

- 7.** Tout en se reportant à la figure ci-dessous, faire passer les autres extrémités des câbles raccordés au point 5 du bas vers le haut du panneau avant.

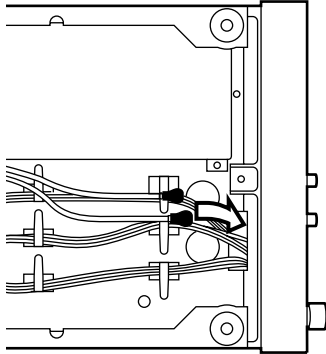

- 10.** Insérer la carte dans l'emplacement à l'extrême gauche de l'AJ-BS900, et refixer la pièce métallique, qui a été dégagée au point 8, à sa position d'origine. Lorsqu'on fixe la pièce métallique, faire attention de ne pas coincer les câbles.

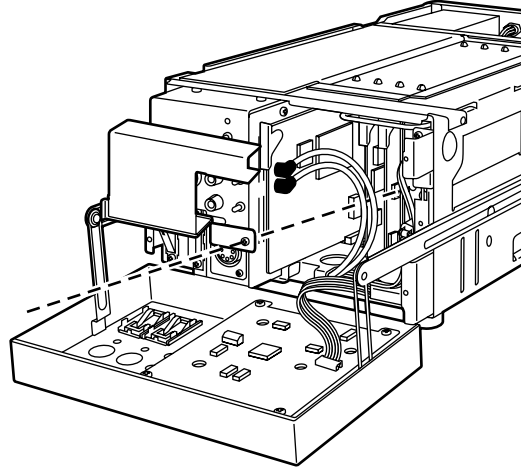

- 8.** Retirer la vis sur le panneau avant du couvercle retiré de l'AJ-BS900, et dégager la pièce métallique indiquée sur la figure ci-dessous. (La vis ne se détache pas de la pièce métallique.)

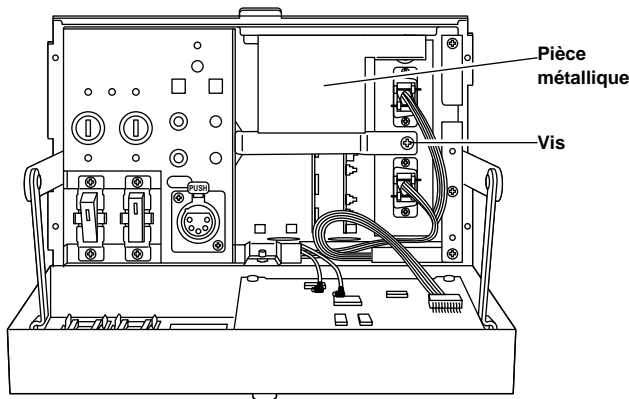

- 11.** Tirer les longueurs excessives de câble vers le bas, et fixer les câbles à l'aide de serre-fils de façon qu'il ne reste pas de jeu dans les câbles.

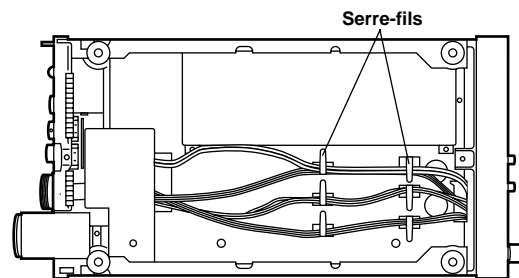

- 9.** Raccorder les extrémités des câbles qui ont été acheminés depuis le fond au point 7 à la carte de façon qu'ils soient tous alignés dans le sens indiqué sur la figure ci-dessous.

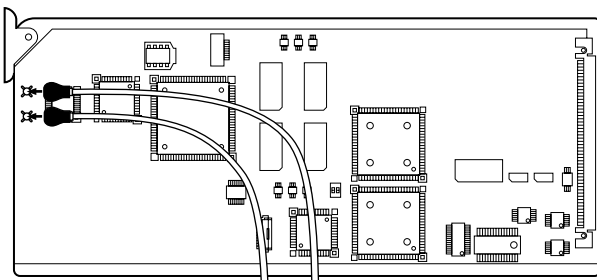

- 12.** Remettre le couvercle du panneau avant, le panneau inférieur et les panneaux latéraux, dans cet ordre, dans leur position d'origine, et les fixer à l'aide des vis respectives.

Fiche technique

Fiche technique

GENERALITES

Poids: 170 g
Dimensions: 230 (W) x 113 (H) x 20 (D) mm

SORTIE VIDEO

Connecteurs de sortie numérique série: BNC x 2
SERIAL OUT 1 : Connecteur de sortie SDI
SERIAL OUT 2 : Connecteur de sortie SDI
SDI : Respecte la norme SMPTE 259M-C.

SORTIE AUDIO

Connecteurs de sortie numérique série: Respectent les normes SMPTE 259M-C/SMPTE 272M-A.

Descrizione/Area connettori

Descrizione

AJ-YA901P/E

Questa scheda di uscita SDI è progettata per l'uso con l'AJ-BS900. La sua installazione nell'AJ-BS900 permette l'uscita digitale dei dati usando il formato SDI.

Per l'installazione della scheda di uscita SDI, rivolgersi a personale tecnico qualificato.

Area connettori (AJ-BS900)

Connettori di uscita digitale seriale (BNC x2)

- ❶ Uscita 1: Uscita SDI
- ❷ Uscita 2: Uscita SDI

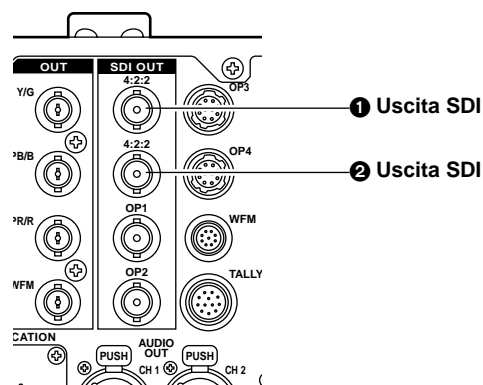

Installazione

Per installare l'AJ-YA901 (chiamata di seguito "scheda") nell'AJ-BS900, usare il procedimento seguente.

1. Facendo riferimento alla illustrazione sotto, togliere le quattro viti dal pannello posteriore dell'AJ-BS900.

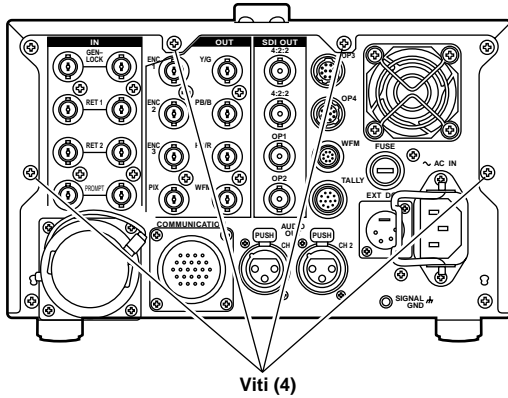

4. Far passare le estremità dei cavi attaccati alla scheda dalla posizione in basso, mostrata nella illustrazione, verso la parte superiore del pannello posteriore.

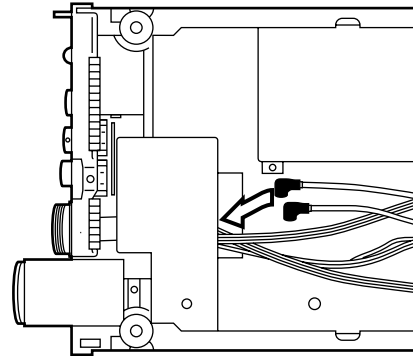

2. Togliere le due viti da ciascun pannello laterale destro e sinistro dell'AJ-BS900 e rimuovere i pannelli laterali.

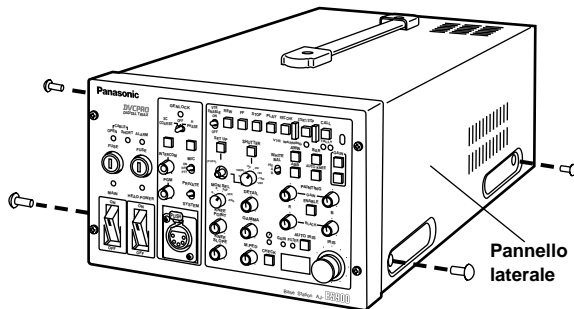

5. Collegare i cavi, inseriti nell'AJ-BS900 al passo 4, al lato interno dei connettori di uscita SDI. Per i dettagli sulle posizioni di questi connettori, riferirsi alla illustrazione sotto e a "Area connettori" (pag. I-1).

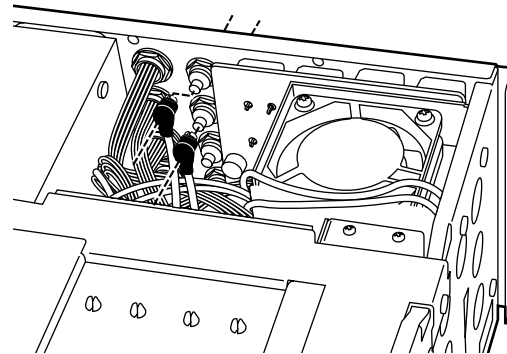

3. Togliere le due viti dal pannello inferiore dell'AJ-BS900 e rimuovere il pannello inferiore.

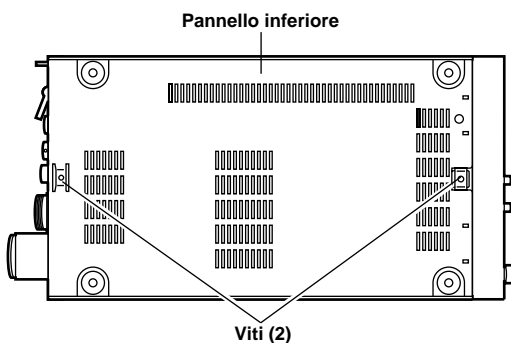

6. Togliere le quattro viti sul pannello anteriore dell'AJ-BS900 e tirar via il coperchio del pannello anteriore. (Non è possibile togliere la viti sul pannello anteriore.)

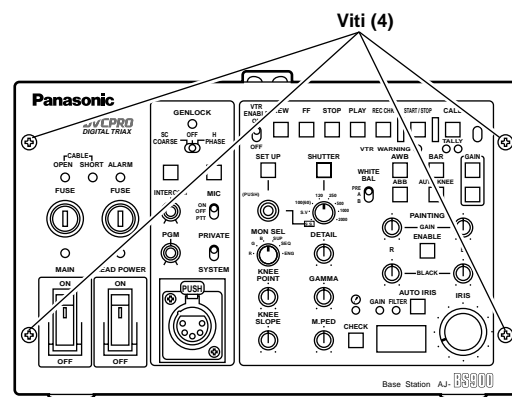

Installazione

- 7.** Facendo riferimento alla illustrazione sotto, far passare l'altra estremità dei cavi collegati al passo 5 dal basso verso la parte superiore del pannello anteriore.

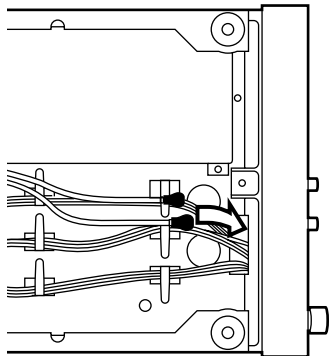

- 10.** Inserire la scheda nello slot più a sinistra dell'AJ-BS900 e riattaccare nella sua posizione originale la piastrina metallica liberata al passo 8. Quando si attacca la piastrina metallica, fare attenzione a non incastrare i cavi.

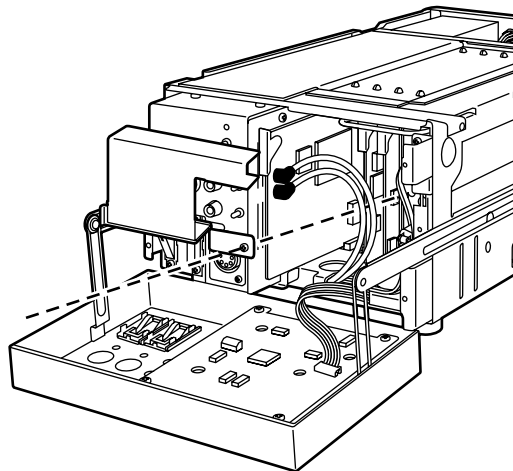

- 8.** Togliere la vite dal pannello anteriore del coperchio rimosso dall'AJ-BS900 e liberare la piastrina metallica mostrata nella illustrazione sotto. (Non è possibile togliere la vite dalla piastrina metallica.)

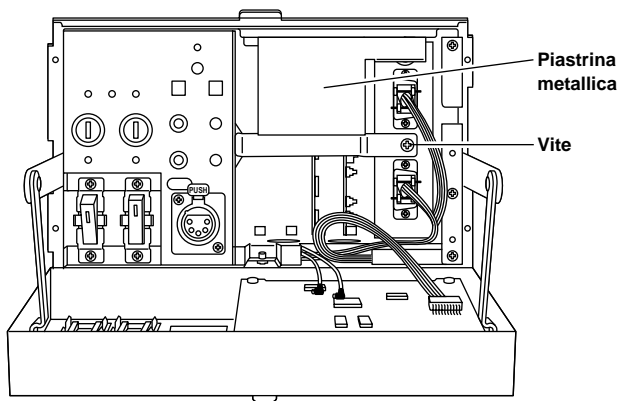

- 11.** Tirare in basso l'eccesso dei cavi e fissarli usando i morsetti dei cavi in modo che non siano allentati.

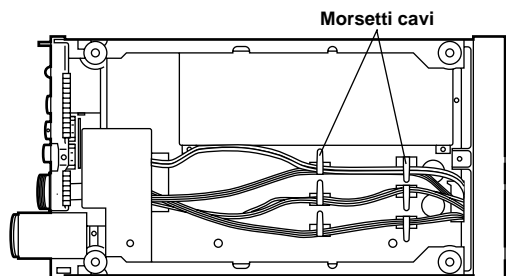

- 9.** Collegare alla scheda le estremità dei cavi, fatti passare dal fondo al passo 7, in modo che siano allineati nelle direzioni mostrate nella illustrazione sotto.

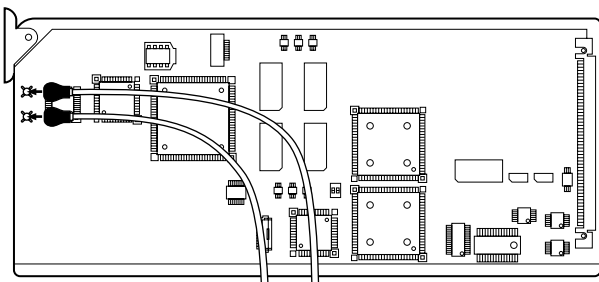

- 12.** Rimettere nelle loro posizioni originali il coperchio del pannello anteriore, il pannello inferiore e i pannelli laterali, in quest'ordine, e fissarli con le rispettive viti.

Dati tecnici

Dati tecnici

GENERALI

Peso: 170 g
Dimensioni (L x A x P): 230 x 113 x 20 mm

USCITA VIDEO

Connettori di uscita digitale seriale: BNC x 2
SERIAL OUT 1: Connettore di uscita SDI
SERIAL OUT 2: Connettore di uscita SDI
SDI: Conforme allo standard SMPTE 259M-C

USCITA AUDIO

Connettori di uscita digitale seriale: Conformi agli standard SMPTE 259M-C/SMPTE 272-A

Perspectiva general/Área de conectores

Perspectiva general

AJ-YA901P/E

Esta tarjeta de interfaz SDI ha sido diseñada para ser utilizada con la AJ-BS900.

Su instalación en la AJ-BS900 permite dar salida a datos digitales utilizando el formato SDI.

Cuando instale la tarjeta de interfaz SDI, consulte al personal de servicio cualificado.

Área de conectores (AJ-BS900)

Conectores de salida digital serial (2 BNC)

- ❶ Salida 1: Salida SDI
- ❷ Salida 2: Salida SDI

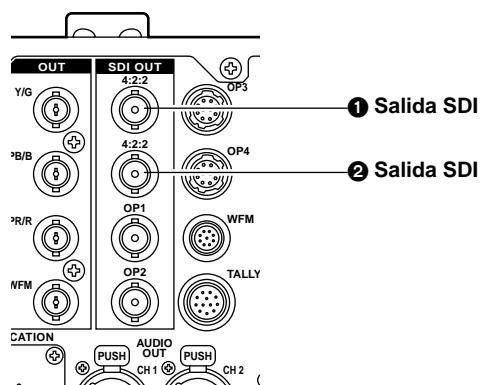

Instalación

Siga los pasos de abajo para instalar la AJ-YA901 (a partir de ahora "la tarjeta") en la AJ-BS900.

1. Consulte la figura de abajo y retire los cuatro tornillos del panel trasero de la AJ-BS900.

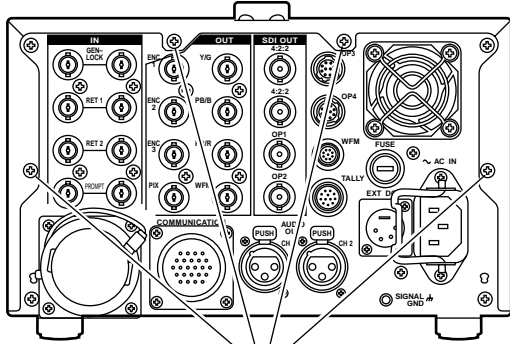

Tornillos (4)

4. Pase los extremos de los cables colocados en la tarjeta desde la posición inferior, mostrada en la figura de abajo, hacia la parte superior del panel trasero.

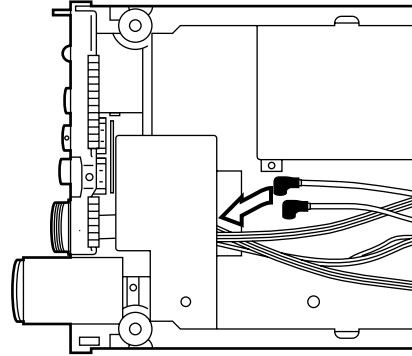

2. Retire los dos tornillos de cada panel lateral derecho e izquierdo de la AJ-BS900 para poder quitar los paneles laterales.

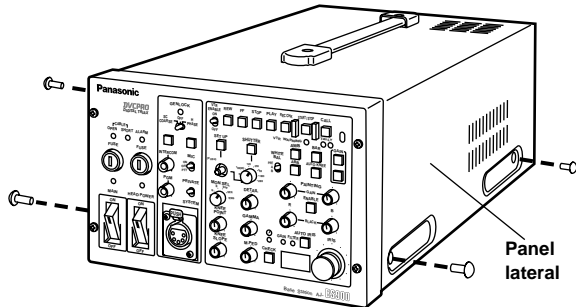

Panel lateral

5. Conecte los cables, que fueron insertados en la AJ-BS900 en el paso 4, en el lado interior de los conectores de salida SDI. Para conocer detalles de las posiciones de estos conectores, consulte la figura de abajo y "Área de conectores" (página S-1).

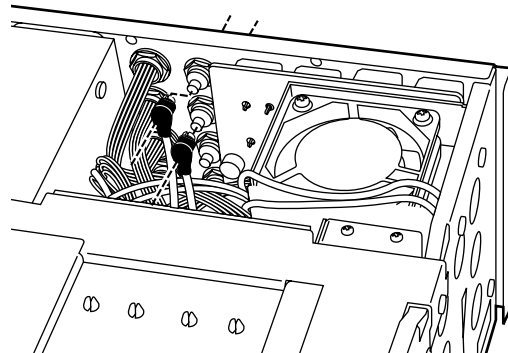

3. Retire los dos tornillos del panel inferior de la AJ-BS900 para retirar el panel inferior.

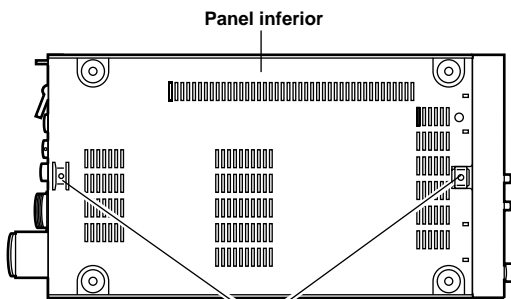

Tornillos (2)

6. Retire los cuatro tornillos del panel delantero de la AJ-BS900 y retire la cubierta del panel delantero. (El tornillo no puede quitarse del panel delantero.)

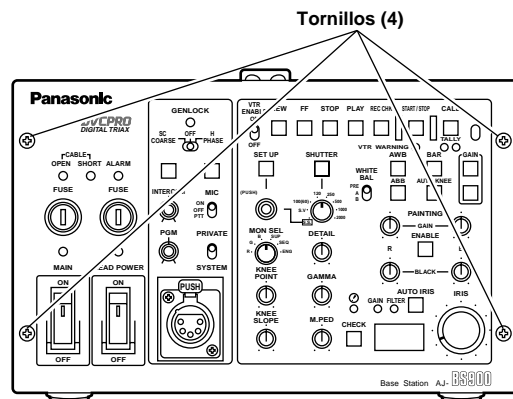

Tornillos (4)

Instalación

- 7.** Mientras consulta la figura de abajo, pase los otros extremos de los cables conectados en el paso 5 desde la parte inferior hacia la parte superior del panel delantero.

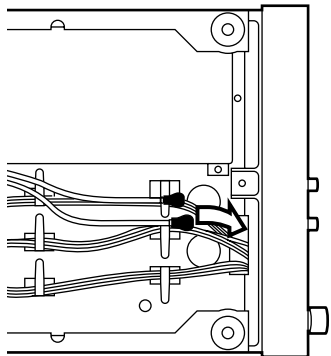

- 10.** Inserte la tarjeta en la ranura del extremo izquierdo de la AJ-BS900, y vuelva a colocar la pieza metálica que fue soltada en el paso 8 en su posición original. Cuando asegure la pieza metálica, asegúrese de que los cables no estén pellizcados.

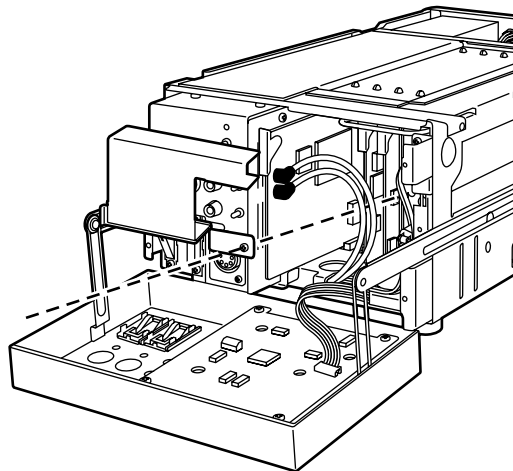

- 8.** Retire los tornillos del panel delantero de la cubierta retirada de la AJ-BS900, y suelte la pieza metálica mostrada en la figura de abajo. (El tornillo no puede quitarse de la pieza metálica.)

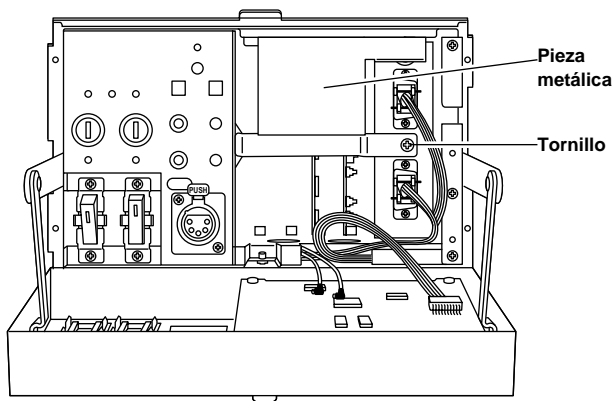

- 11.** Saque el exceso de los cables hacia la parte inferior, y fije los cables con abrazaderas de forma que no queden flojos.

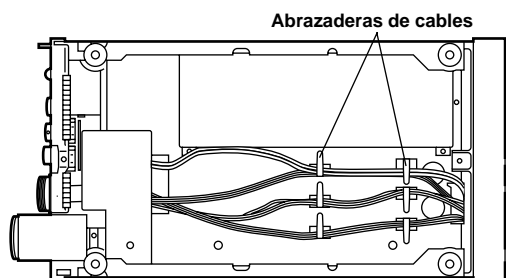

- 9.** Conecte los extremos de los cables que fueron pasados desde la parte inferior en el paso 7 a la tarjeta de forma que queden alineados en los sentidos mostrados en la figura de abajo.

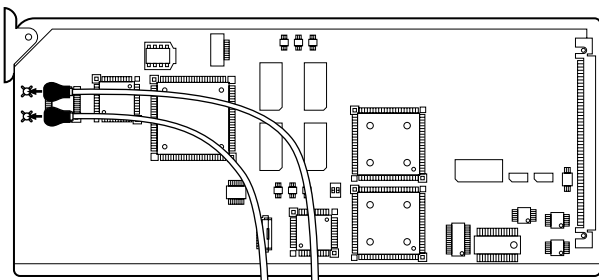

- 12.** Vuelva a poner la cubierta del panel delantero, el panel inferior y los paneles laterales en sus posiciones originales en este orden, y asegúrelos mediante sus tornillos respectivos.

Especificaciones

Especificaciones

GENERALIDADES

Peso: 170 g
Dimensiones: 230 (An) x 113 (Al) x 20 (Prof) mm

SALIDA DE VÍDEO

Conectores de salida digital serial: 2 BNC
SALIDA SERIAL 1: Conector de salida SDI
SALIDA SERIAL 2: Conector de salida SDI
SDI: Cumple con la norma SMPTE 259M-C

SALIDA DE AUDIO

Conectores de salida digital serial: Cumplen con las normas SMPTE 259M-C/SMPTE 272M-A

概要／コネクタ部

概要

AJ-YA901P/E

本製品はAJ-BS900用SDIアウトプットボードです。本製品をAJ-BS900に装着することにより、SDIフォーマットを用いたデジタルデータの出力が可能になります。

SDIアウトプットボードの取り付けの際には、必ず販売店にご相談ください。

コネクタ部 (AJ-BS900)

シリアルデジタル出力 (BNC×2)

- ① 出力1：SDI出力
- ② 出力2：SDI出力

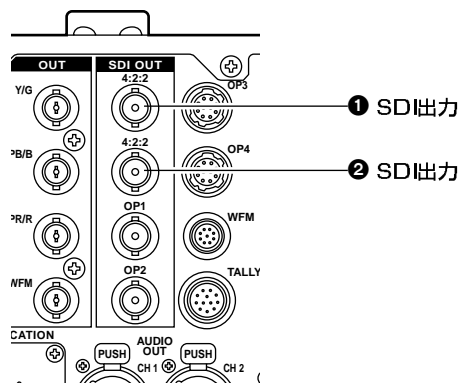

取り付け

AJ-YA901（以下、本ボード）のAJ-BS900への取り付けは以下の手順で行ってください。

1. AJ-BS900の背面から、下図を参照し4本のビスを外します。
4. 本ボードに付属のケーブルを、底面の下図の位置から背面の上部に向けて先端から通します。

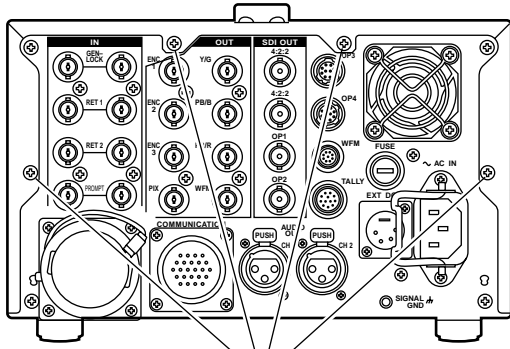

ビス(4本)

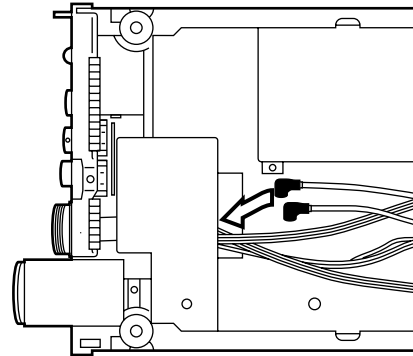

2. AJ-BS900の側面から、左右2本ずつビスを外し、側板を外します。
5. 4. で差し込んだケーブルをSDI出力端子の内側に接続します。端子の位置は下図、および「コネクタ部」(J-1ページ)の図を参照してください。

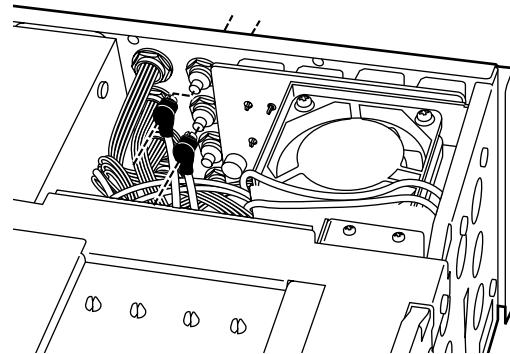
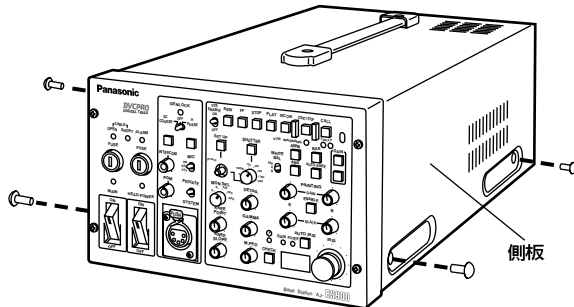

3. AJ-BS900の底面から2本ビスを外し、底板を外します。
6. AJ-BS900のフロントパネル部にあるビスを4本外し、正面のカバーを引き出します。(このとき、フロントパネルのカバーからビスは外れません)

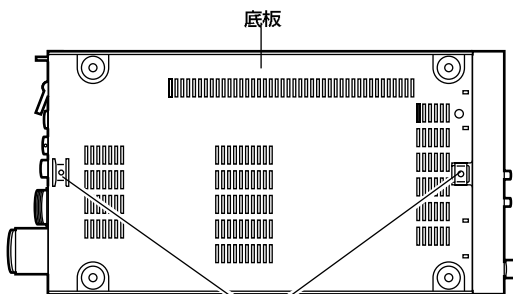

ビス(2本)

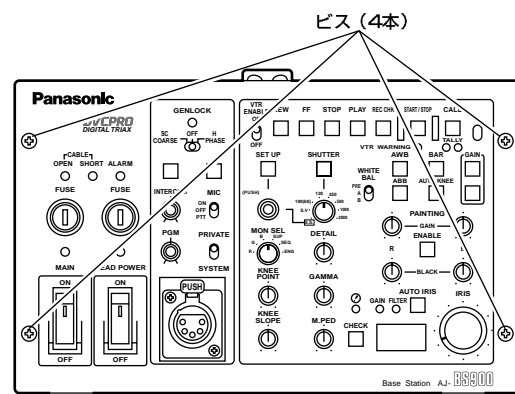

ビス(4本)

取り付け

7. 5. で接続したケーブルのもう片方の先を、下図を参照して底面から正面上部に向けて先端から通します。

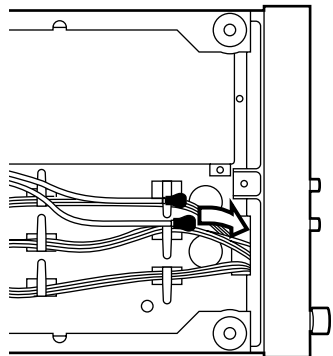

10. 本ボードをAJ-BS900の一番左のスロットにさし、8. で外した金具を元の位置に取り付けます。金具を止めるとき、ケーブルをはさまないようにしてください。

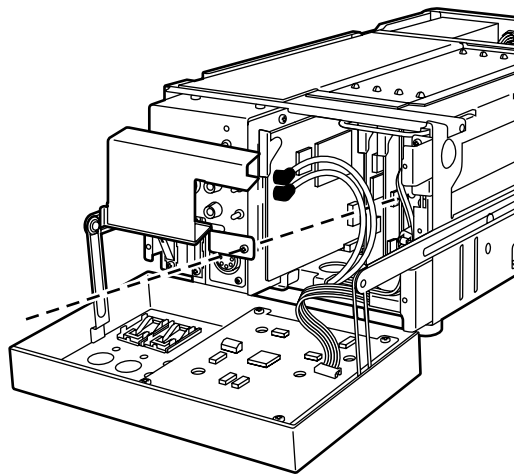

8. カバーを外したAJ-BS900の正面から、ビスを1本外し、下図の金具を外します。(このとき、金具からビスは外れません)

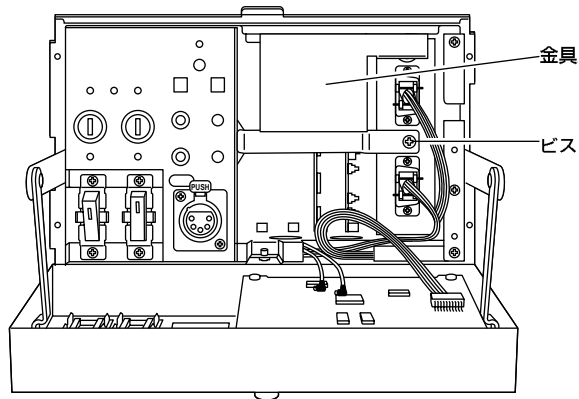

11. 余ったケーブルは底面に引き出し、たるまないようにケーブルクランプで止めます。

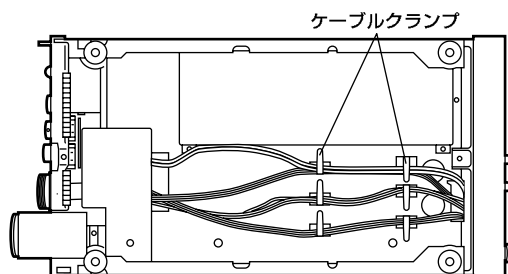

9. 7. で底面から通したケーブルを、下図で示した方向になるように本ボードに接続します。

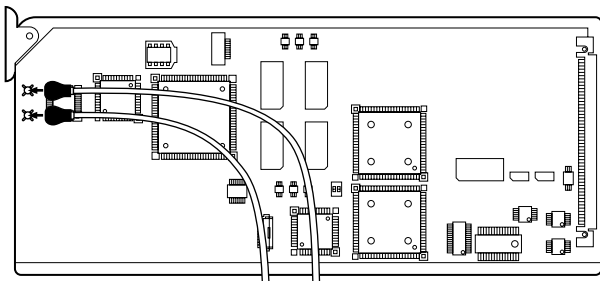

12. 正面のカバー、底板、側板の順に、それぞれビスで止めます。

定 格

定格

総合

重 量 : 170g
外形寸法 : 230 (幅) × 113 (高さ) × 20 (奥行) mm

ビデオ出力

シリアルデジタル出力 : BNC×2
SERIAL OUT 1 : SDI出力
SERIAL OUT 2 : SDI出力
SDI : SMPTE 259M-C準拠

オーディオ出力

シリアルデジタル出力 : SMPTE 259M-C/SMPTE 272M-A準拠

Panasonic

PANASONIC BROADCAST & DIGITAL SYSTEMS COMPANY
DIVISION OF MATSUSHITA ELECTRIC CORPORATION OF AMERICA

Executive Office:

3330 Cahuenga Blvd W., Los Angeles, CA 90068 (323) 436-3500

EASTERN ZONE:

One Panasonic Way 4E-7, Secaucus, NJ 07094 (201) 348-7621

Mid-Atlantic/New England:

One Panasonic Way 4E-7, Secaucus, NJ 07094 (201) 348-7621

Southeast Region:

1225 Northbrook Parkway, Ste 1-160, Suwanee, GA 30024 (770) 338-6835

Central Region:

1707 N Randall Road E1-C-1, Elgin, IL 60123 (847) 468-5200

WESTERN ZONE:

3330 Cahuenga Blvd W., Los Angeles, CA 90068 (323) 436-3500

Dallas Region:

6226 Abington Way, Houston, TX 77008 (713) 802-2726

No. CA/Northwest Region:

5870 Stoneridge, #3, Pleasanton, CA 94588 (925) 416-5108

Government Marketing Department:

52 West Gude Drive, Rockville, MD 20850 (301) 738-3840

PARTS INFORMATION & ORDERING:

9:00 a.m. – 5:00 p.m. (EST) (800) 334-4881/24 Hr. Fax (800) 334-4880

TECHNICAL SUPPORT:

Emergency 24 Hour Parts & Service (800) 222-0741

TRAINING INFORMATION:

Digital System Products - (201) 392-6852

Panasonic Canada Inc.

5770 Ambler Drive, Mississauga, Ontario L4W 2T3 (905) 624-5010

Panasonic de Mexico S.A. de C.V.

Av angel Urraza Num. 1209 Col. de Valle 03100 Mexico, D.F. (52) 1 951 2127

Panasonic Broadcast Europe

Panasonic Broadcast Europe Ltd

West Forest Gate, Wellington Road, Wokingham, Berkshire RG40 2AQ U.K. Tel: 0118 902 9200

Panasonic Broadcast Europe GmbH

Hagenauer Str. 43, 65203 Wiesbaden-Biebrich Deutschland Tel: 49-611-1816-0

松下電器産業株式会社 AVC社 システム事業グループ

☎ 571-8503 大阪府門真市松葉町2番15号 ☎ (06) 6901-1161

Printed in Japan
VQT8892

F1000T 